

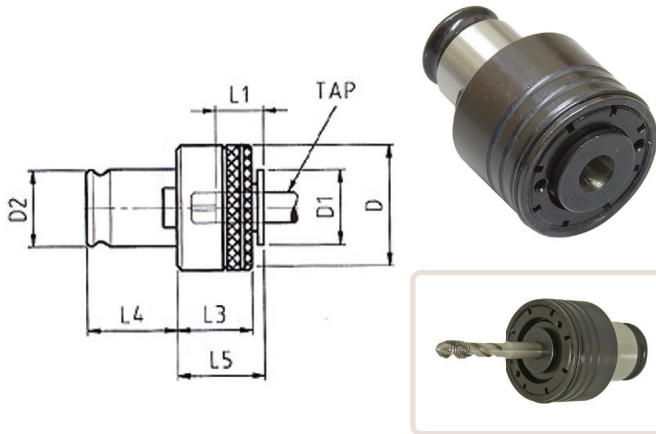

Tapping Collet Technical

Type 1 Collets



D	D1	D2	L1	L3	L4	L5
32	19	19	17	25	21.5	15

All dimension mm

ISO 529 Tapping Collet Sizes

Part no	Size	Shank	Square
TA-CO-T1-M2.5	M2.5	2.8	2.24
TA-CO-T1-M3	M3	3.15	2.5
TA-CO-T1-M4	M4	4	3.15
TA-CO-T1-M4.5	M4.5	3.55	2.8
TA-CO-T1-M5	M5	5	4
TA-CO-T1-M6	M6	6.3	5
TA-CO-T1-M8	M8	8	6.3
TA-CO-T1-M10	M10	10	8
TA-CO-T1-M12	M12	9	7.1
TA-CO-T1-M14	M14	11.2	9

All dimension mm

DIN 371 Tapping Collet Sizes

Part no	Size	Shank	Square
TA-CO-T1-M3-371	M3	3.5	2.7
TA-CO-T1-M4-371	M4	4.5	3.4
TA-CO-T1-M5-371	M5	6	4.9
TA-CO-T1-M6-371	M6	6	4.9
TA-CO-T1-M8-371	M8	8	6.2
TA-CO-T1-M10-371	M10	10	8

All dimension mm

ANSI Tapping Collet Sizes

Part no	Size	Shank	Square
TA-CO-T1-N00-AN	No. 0	0.141	0.110
TA-CO-T1-1-8-AN	1/8	0.141	0.110
TA-CO-T1-1-16AN	1/16	0.141	0.110
TA-CO-T1-3-32-AN	3/32	0.141	0.110
TA-CO-T1-5-32-AN	5/32	0.168	0.131
TA-CO-T1-N08-AN	No. 8	0.168	0.131
TA-CO-T1-N10-AN	No. 10	0.194	0.152
TA-CO-T1-N12-AN	No. 12	0.220	0.165
TA-CO-T1-N14-AN	No. 14	0.225	0.191
TA-CO-T1-1-4-AN	1/4	0.225	0.191
TA-CO-T1-5-16-AN	5/16	0.318	0.238
TA-CO-T1-7-16-AN	7/16	0.323	0.242
TA-CO-T1-1-2-AN	1/2	0.367	0.275
TA-CO-T1-3-18-AN	3/8	0.381	0.286

All dimension inches

Type 2 Collets

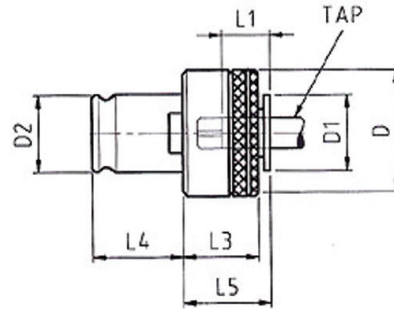

D	D1	D2	L1	L3	L4	L5
50	30	31	30	31	35	33

All dimension mm



ISO 529 Tapping Collet Sizes

Part no	Size	Shank	Square
TA-CO-T2-M6	M6	6.3	5
TA-CO-T2-M8	M8	8	6.3
TA-CO-T2-M10	M10	10	8
TA-CO-T2-M12	M12	9	7.1
TA-CO-T2-M14	M14	11.2	9
TA-CO-T2-M16	M16	12.5	10
TA-CO-T2-M18	M18	14	11.2
TA-CO-T2-M20	M20	14	11.2
TA-CO-T2-M22	M22	16	12.5
TA-CO-T2-M24	M24	18	14

All dimensions mm

DIN 371 and 376 Tapping Collet Sizes

Part no	Size	Shank	Square
TA-CO-T2-M5-371	M5	6	4.9
TA-CO-T2-M6-371	M6	6	4.9
TA-CO-T2-M8-376	M8	6	4.9
TA-CO-T2-M10-376	M10	7	5.5
TA-CO-T2-M12-376	M12	9	7
TA-CO-T2-M14-376	M14	11	9
TA-CO-T2-M16-376	M16	12	9
TA-CO-T2-M20-376	M20	16	12
TA-CO-T2-M22-376	M22	18	14.5
TA-CO-T2-M24-376	M24	18	14.5

All dimension mm





Type 3 Collets

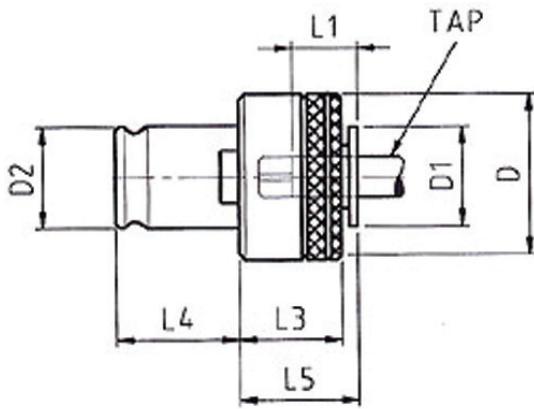

D	D1	D2	L1	L3	L4	L5
32	19	19	17	25	21.5	15

All dimension mm



DIN 352 Tapping Collet Sizes

Part no	Size	Shank	Square
TA-CO-T3-M24-352	M24	18	14.5
TA-CO-T3-M27-352	M27	20	16
TA-CO-T3-M30-352	M30	22	18
TA-CO-T3-M33-352	M33	25	20
TA-CO-T3-M36-352	M36	28	22
TA-CO-T3-M42-352	M42	32	26

All dimension mm

Drill Chuck Quick Change Collets

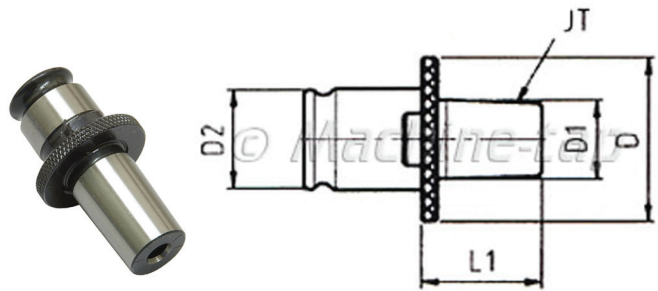

Part no	Collet Size	Chuck Size	JT	D	D1	D2	L1
TA-CO-T1-JT2	Type 1	JT2	2	30	13.94	19	31
TA-CO-T1-JT6	Type 1	JT6	6	30	17.17	19	34
TA-CO-T2-JT6	Type 2	JT6	6	48	17.17	31	37

All dimension mm

Collet Adaptors

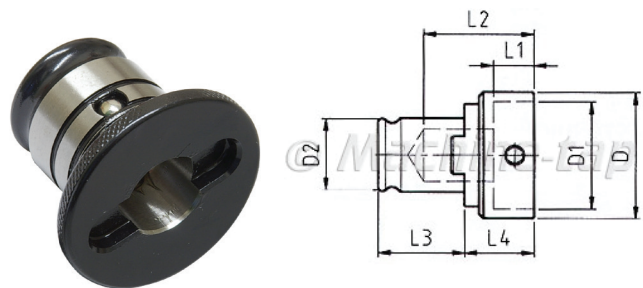

Part no	Collet Size	D	D1	D2	L1	L3
TA-CO-T2-T1	Type 2	50	38.5	31	4	35
TA-CO-T3-T2	Type 3	69	70	48	5.5	56

All dimension mm

