



1000 Series Tapping Arm

Doc V: 1.0



Angle Head models TA-1000-16-AN and TA-1000-22-AN

Model Number	Tapping Range	Working Area		RPM	Collet Type	Weight
		Min	Max			
TA-1000-16	M5 to M16	100	1000	300	TYPE 2	29Kg
TA-1000-16-AN	M5 to M16	100	1000	300	TYPE 2	29Kg
TA-1000-22	M5 to M22	100	1000	120 / 300	TYPE 2	29Kg
TA-1000-22-AN	M5 to M22	100	1000	120 / 300	TYPE 2	29Kg
TA-1000-27	M5 to M27	100	1000	70 / 220	TYPE 2	29Kg

Quick Change Collet Chuck



The pneumatic motor is equipped with a chuck and each tap is held in its own collet (collets supplied separately). To change to a different tap size, lift the locking ring on the chuck. This will eject the collet from the motor. Select the collet with the desired tap size. Insert the collet into the chuck. Locate the two drive pegs on the collet and release the locking ring to secure.

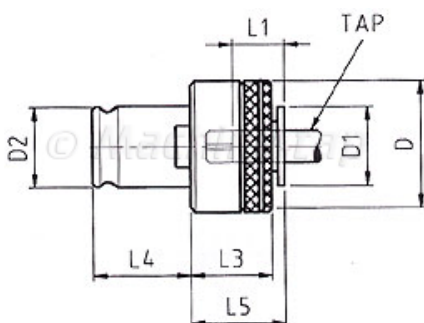

Collet Type	D	D1	D2	L1	L3	L4	L5
TYPE 1	23	12.5	13	15	20	19.5	21
TYPE 2	50	30	31	30	31	35	33